

TWIST EXPRESS RS

ALUXX
Aluminum Technology

HYBRID
CYCLING TECHNOLOGY.



SPECIFICATIONS

FRAME	SIZES	M, L
	COLOURS	Matte Black/Blue
	FRAME	ALUXX-Grade aluminum
	FORK	Rigid alloy
	SHOCK	N/A
COMPONENTS	HANDLEBAR	Alloy, high rise
	STEM	Alloy, adjustable
	SEATPOST	Suspension, 27.2mm
	SADDLE	Unity Comfort Groove +
	PEDALS	Comfort platform
DRIVETRAIN	SHIFTERS	SRAM MRX Pro, twist
	FRONT DERAILLEUR	N/A
	REAR DERAILLEUR	Shimano Altus
	BRAKES	Alloy, direct pull
	BRAKE LEVERS	Tektro Alloy
	CASSETTE	Shimano 11-28T, 7SPD
	CHAIN	KMC Z51
	CRANKSET	Alloy 3PC, 46T
	BOTTOM BRACKET	Cartridge
	WHEELS	RIMS
HUBS		[F] SyncDrive Motor [R] Alloy
SPOKES		Stainless steel, 14g
TIRES		Kenda w/ Slime tubes, 700x35c
EXTRAS		Lithium Ion 36V EnergyPak w/ charger, rear alloy rack w/storage case & EnergyPak lock, fenders, kickstand, bell

FEATURES

- ALUXX- Grade aluminum frame w/ rigid fork
- SRAM MRX Pro twist shifters w/ Shimano Altus 7-speed rear derailleur
- 1 lithium-ion battery EnergyPak for lighter weight
- Rear alloy rack w/ storage case

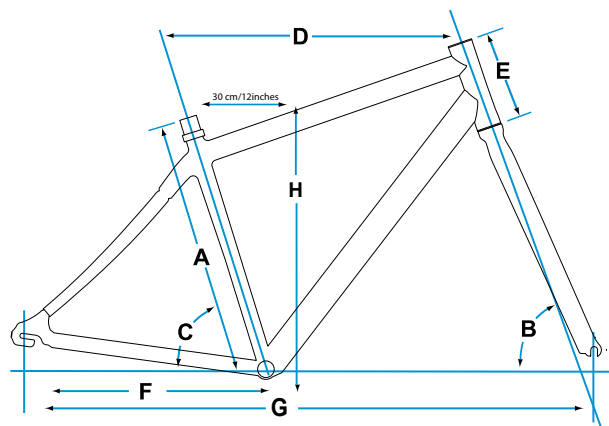

FRAME GEOMETRY

	A	B	C	D	E	F	G	H
Actual Frame Size	Part Number	Head Angle	Seat Angle*	Toptube**	Headtube	Chainstay	Wheelbase	Standover Height***
inches		degrees	degrees	inches	inches	inches	inches	inches
M 17.5	2109890	70.0	72.0	23.0	6.3	19.2	44.0	30.8
L 21.0	2109891	70.0	72.0	23.6	7.1	19.2	44.6	33.5

*Seat angle is actual

**Toptube is measured from the center of the headtube horizontally back to the top of the effective extension of the seattube

***Standover height is based on the largest size tire that will fit the bike, not necessarily the included size tire

