

# TRANSEND LX W



## SPECIFICATIONS

FRAME	SIZES	XS,S,M
	COLOURS	Silver
	FRAME	ALUXX-Grade aluminum
	FORK	Alloy straight blade w/ CroMo steer
	SHOCK	N/A
COMPONENTS	HANDLEBAR	Alloy, low rise, 25.4mm
	STEM	Alloy
	SEATPOST	Alloy, 27.2mm
	SADDLE	Unity Comfort Groove +
	PEDALS	Comfort platform
	DRIVETRAIN	SHIFTERS
FRONT DERAILLEUR		Shimano C102
REAR DERAILLEUR		Shimano Alivio
BRAKES		Hayes MX4, 160mm
BRAKE LEVERS		Shimano EF50
CASSETTE		SRAM PG820, 11-30T, 8SPD
CHAIN		KMC Z72
CRANKSET		Shimano M191, 28/38/48T
BOTTOM BRACKET		Cartridge
WHEELS		RIMS
	HUBS	Formula alloy
	SPOKES	Steel, 14g
	TIRES	Kenda Kwick Trax, 700x35c
	EXTRAS	Rear alloy rack, fenders, kickstand, bell

Specifications and availability subject to change without notice.

## KEY UPGRADES (OVER TRANSEND DX W)

- Hayes MX4 mechanical disc brakes
- Shimano 8-speed drivetrain w/ triple crankset and Shimano Alivio rear derailleur
- Giant Comfort Groove+ saddle
- Includes fenders, kickstand rear alloy rack and bell

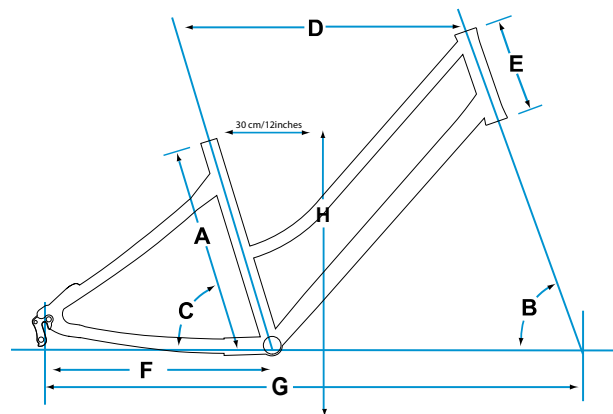

## FRAME GEOMETRY

	A	B	C	D	E	F	G	H
Actual Frame Size	Part Number	Head Angle	Seat Angle*	Toptube**	Headtube	Chainstay	Wheelbase	Standover Height***
inches		degrees	degrees	inches	inches	inches	inches	inches
XS 14	2103106	70.0	74.0	21.4	6.3	17.8	41.6	22.1
S 16	2103107	70.0	73.0	22.1	6.3	17.8	41.8	22.7
M 18	2103108	71.0	73.0	22.6	6.3	17.8	42.3	23.5

\*Seat angle is actual

\*\*Toptube is measured from the center of the headtube horizontally back to the top of the effective extension of the seattube

\*\*\*Standover height is based on the largest size tire that will fit the bike, not necessarily the included size tire

